

FastWash

Elettra Fastwash System



COMPANY PROFILE

EUROPE

Elettra S.r.l. - Established in 1987 Located North of Milan-Italy

E-mail: elettra.commerciale@elettra.lc.it

Web site: www.elettra.lc.it



U.S.A.

Elettra NA - Located in Chicago (Des Plaines)

Sales and service contact

E-mail: sales@elettra-na.com



WORLDWIDE PRESENCE THROUGH LOCAL DISTRIBUTORS



ELETTRA'S FASTWASH

**BLANKET CYLINDER WASHER
and
IMPRESSION CYLINDER WASHER**

Fastwash System Features

Sheet-fed Washing Cycle



- Spray
- Waiting time for perfect liquid distribution
- Pad out and contact

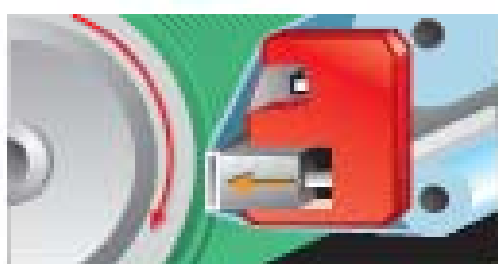

- Pad back and cloth transport
- Repetition of contact cycle

- Repetition of the here above sequences depending on selected washing :

- Short
- Medium
- Long



-
- **Drying contacts**
 - End of wash

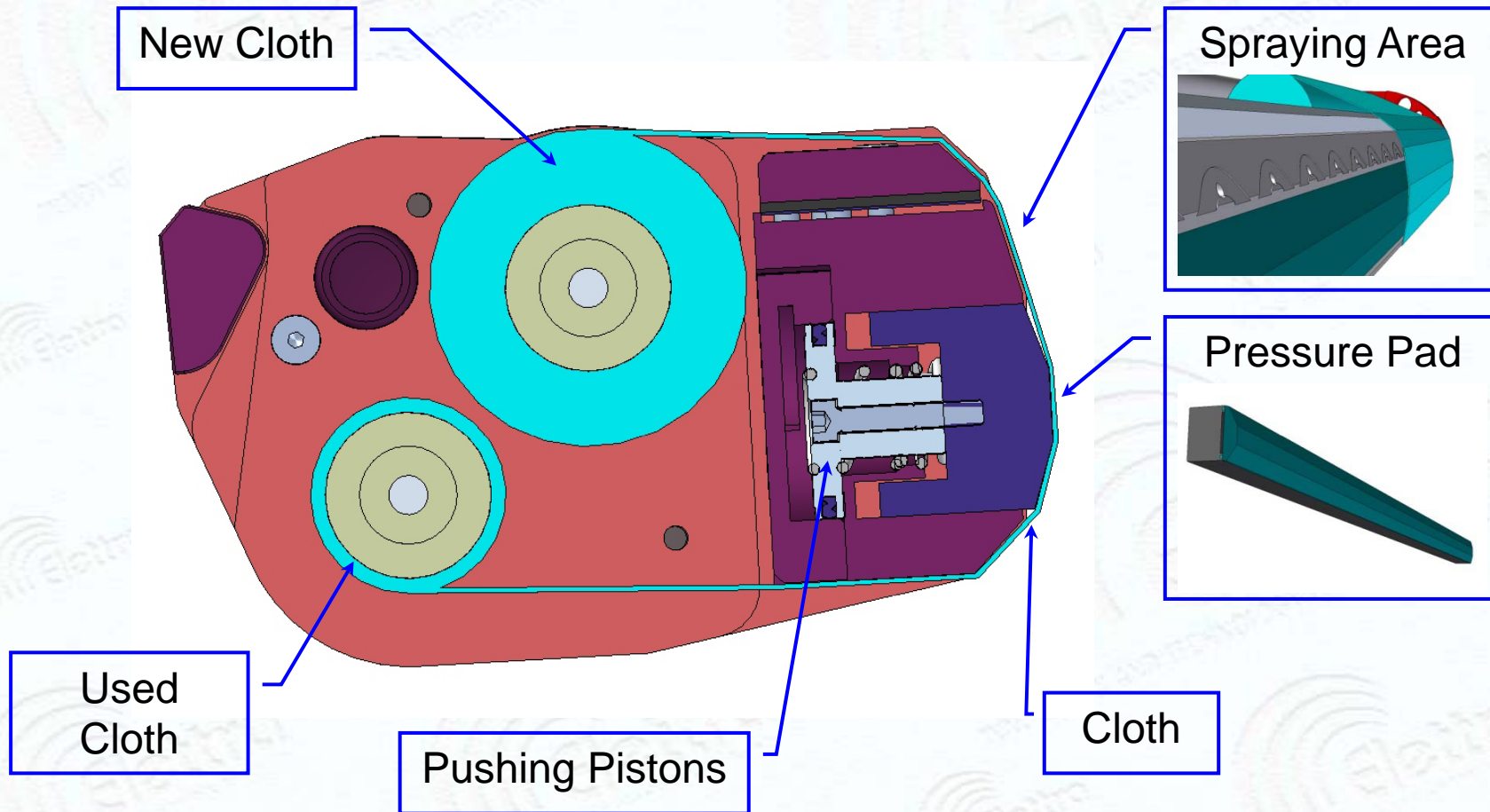

Pivoting washing device is used on KBA Rapida 106

Pivoting Washing Device

One washer to clean both blanket and impression cylinder

**Back -Cylinder
Wash Position**

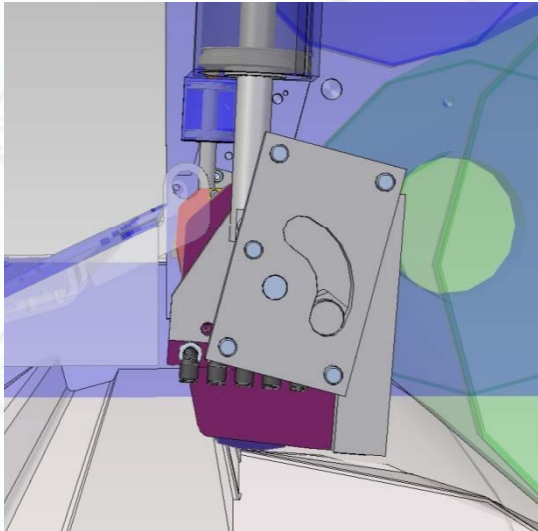

The jump over the grippers will be detected using an Encoder and activating the pneumatic Pistons

**Washer
Rotation**



**Blanket Cylinder
Wash Position**

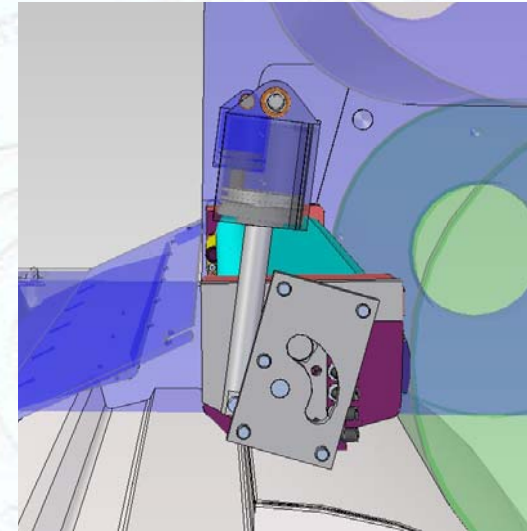



Performances

	BCW	ICW
Press Speed	4500 Rev/h	720 Rev/h
*Medium Washing	About 3 mins	Approx 5 mins
Cloth Consumption per Medium Washing	15 cm	15 cm
Cloth per Roll	12 m	
Medium Washings' number per Roll	Approx 80	Approx 40
Solvent Consumption per Medium Washing	Approx 30 ml	Approx 20 ml
Waste Copies at Printing Re-Start	Less than 10	Less than 10

*3 (three) Washing Cycles Available – Short – Medium - Long

BW CLEANING

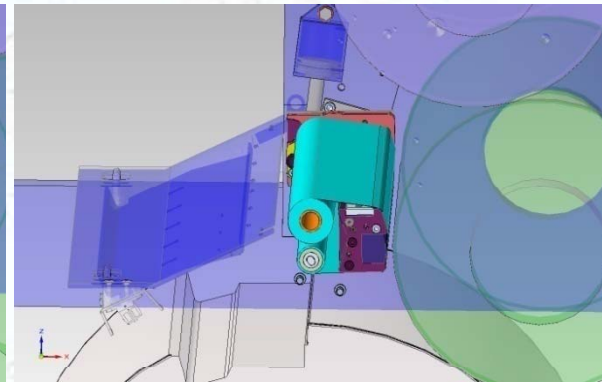
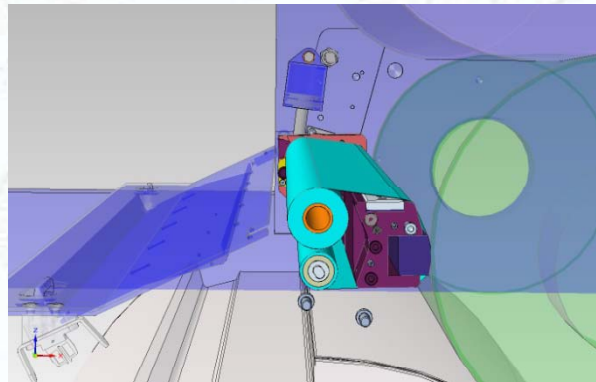
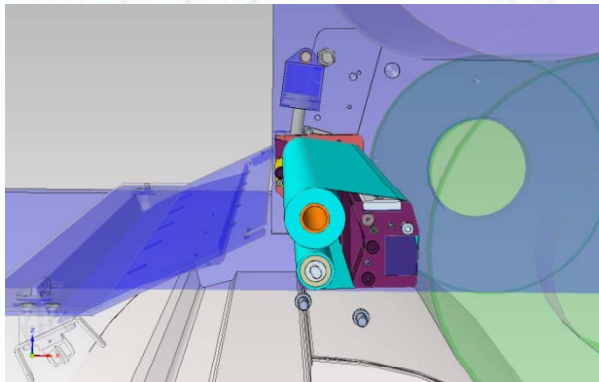

ICW CLEANING

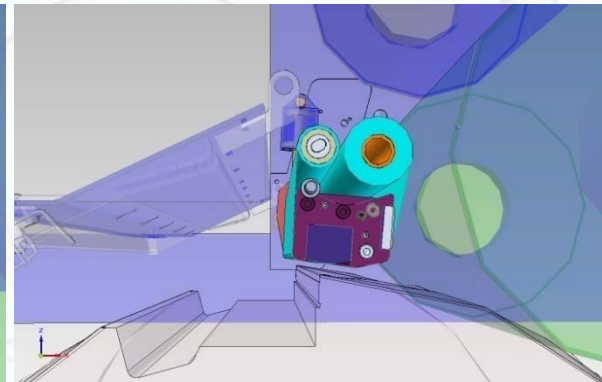
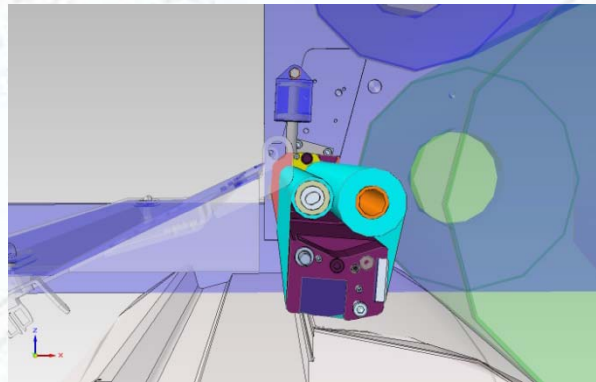
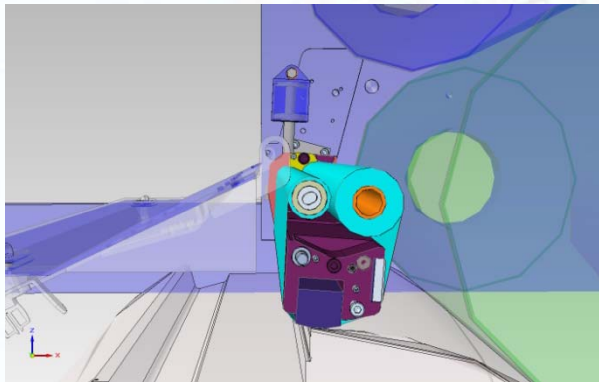



ELETTRA'S FASTWASH

**AVAILABLE ON
NEW and RETROFIT PRESSES**



KBA Rapida 106

With Pivoting washing device

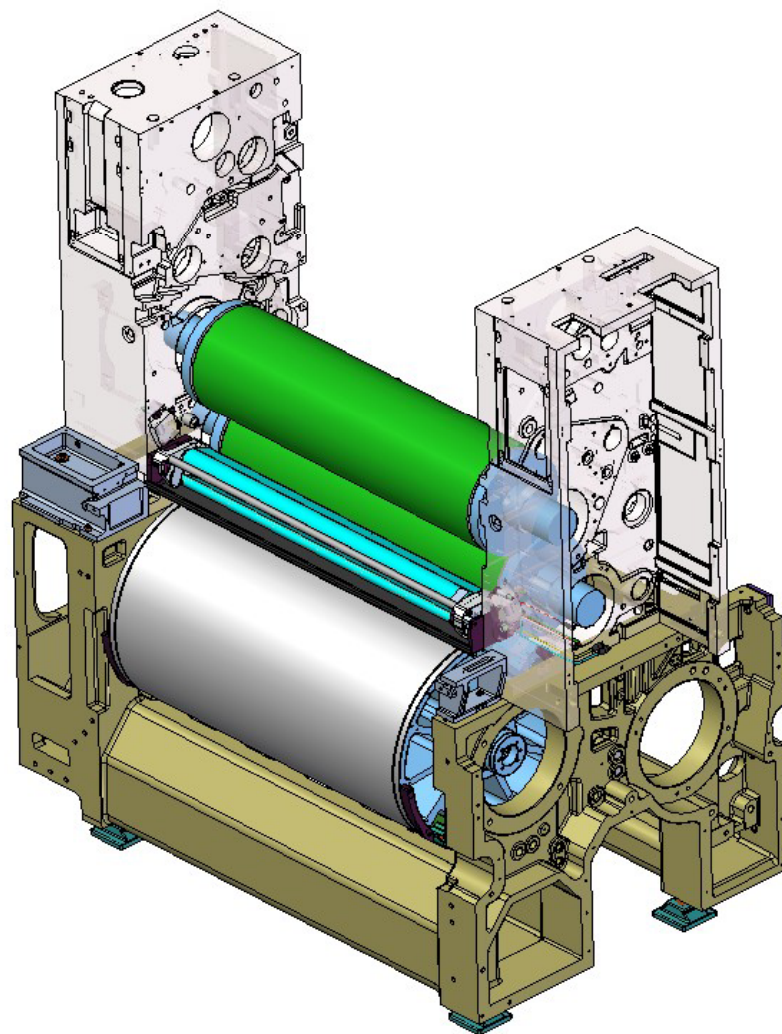

HEIDELBERG 102

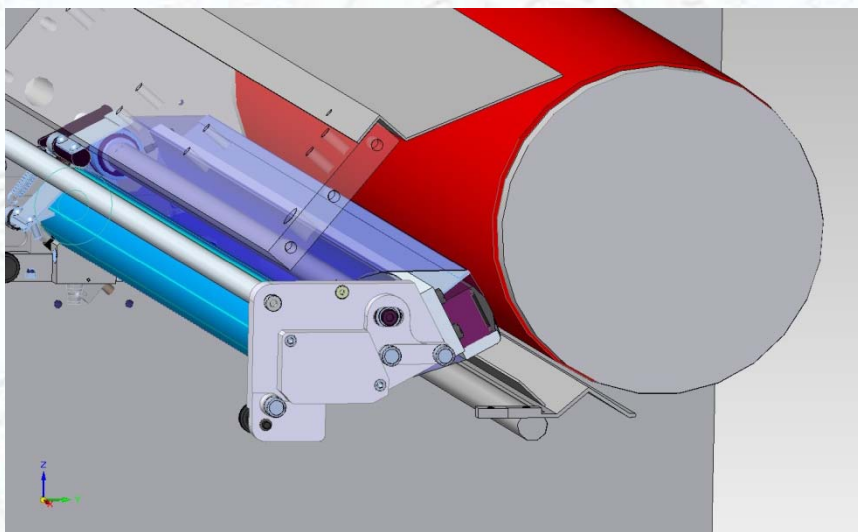
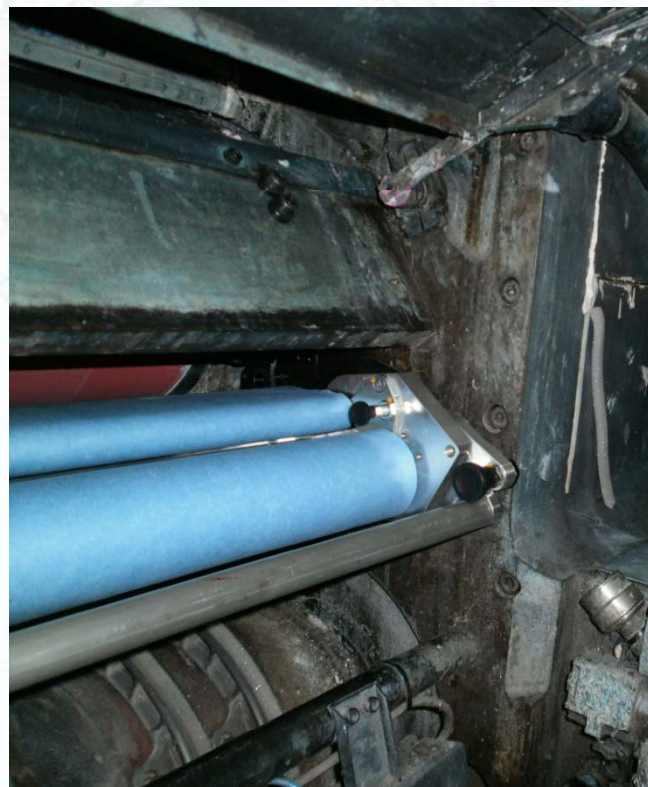
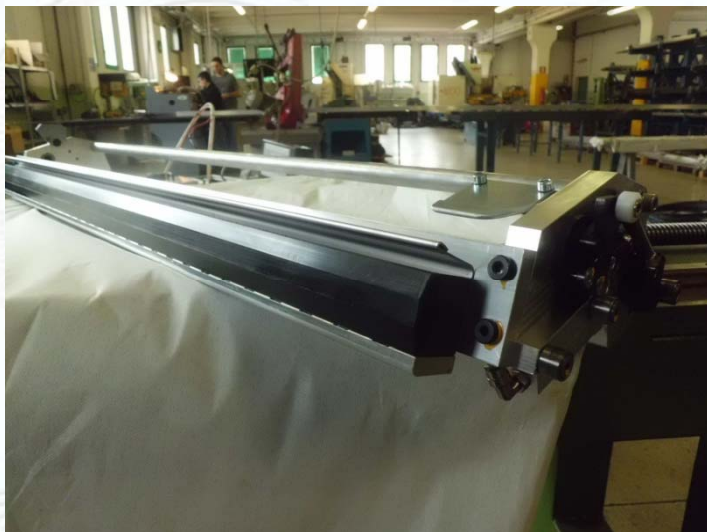



ROLAND 700 - 900

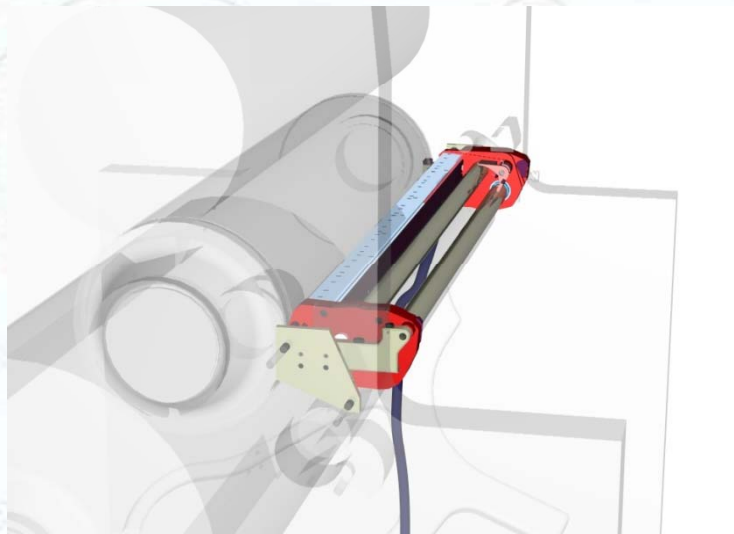

BCW

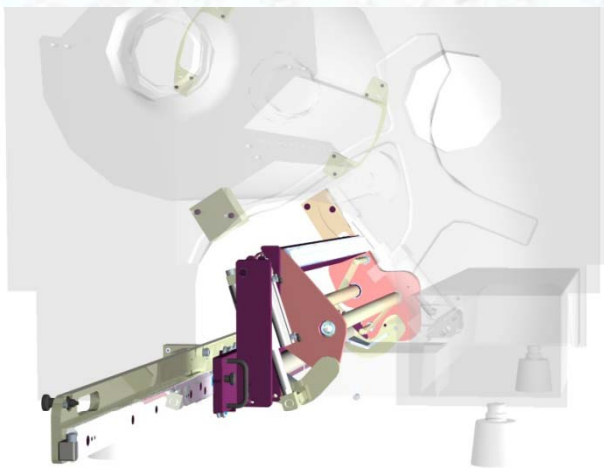

ICW



MHI D3000

WASHING DEVICE ALSO AVAILABLE FOR **MHI D1000**

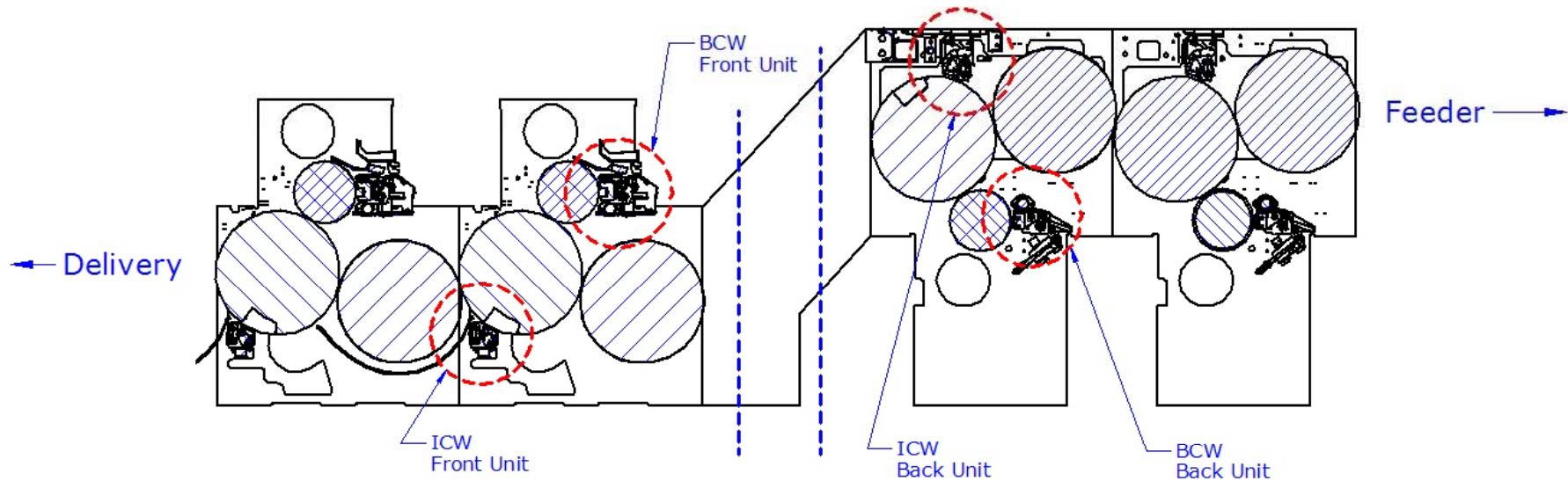

4 Types of Washing Devices



BCW



ICW

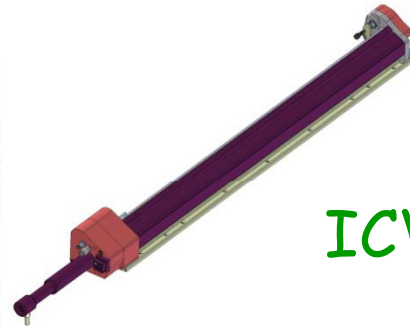

MHI V3000

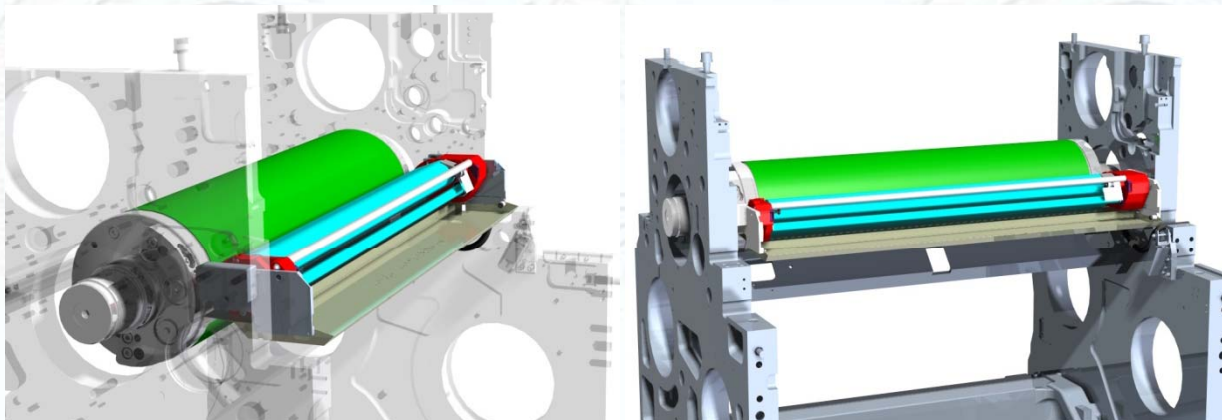

BCW

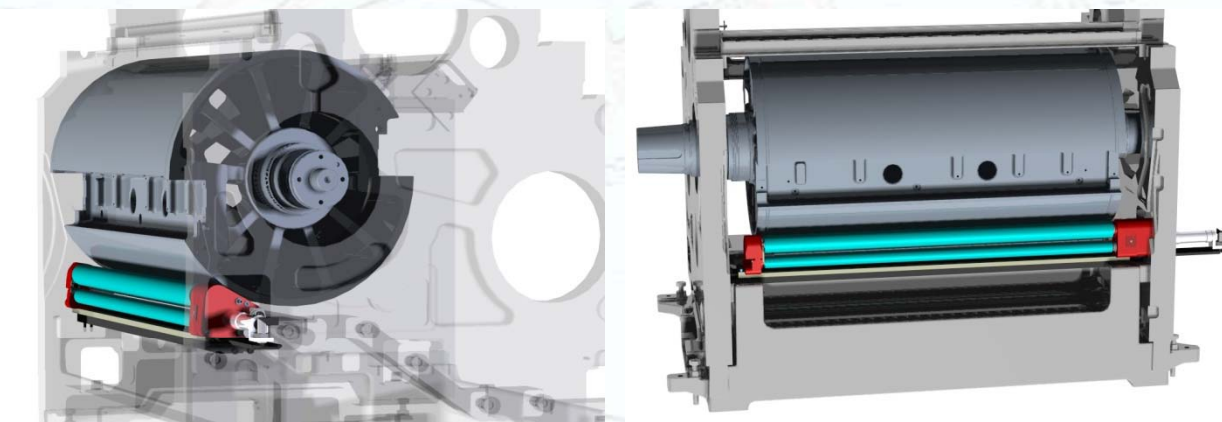

ICW

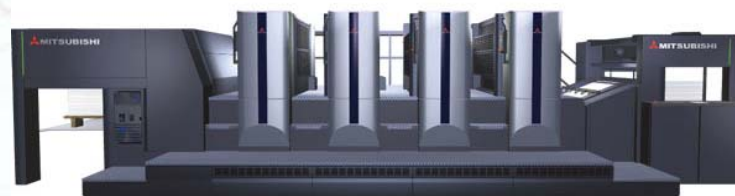

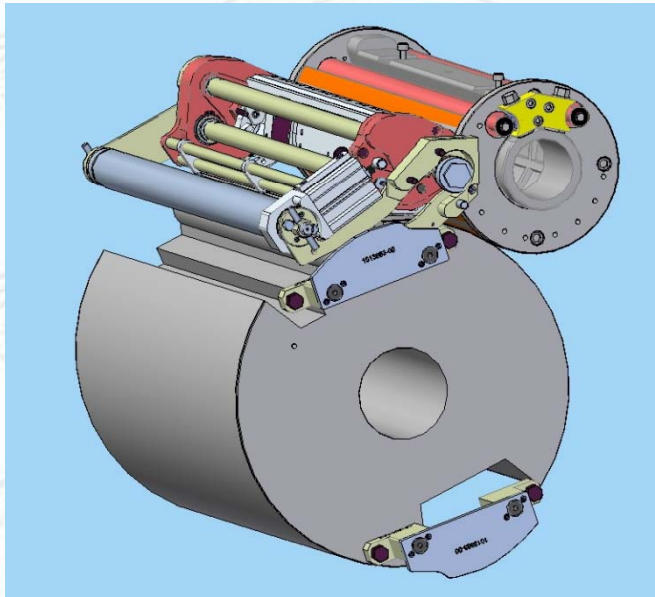
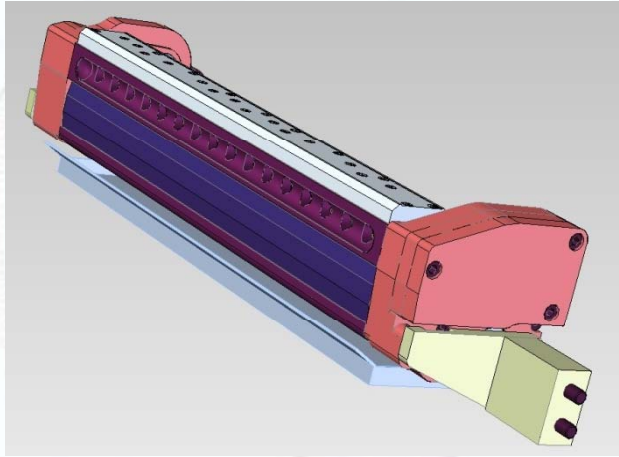

Miyakoshi

Komori

Sakurai



FASTWASH

INK ROLLER WASHER

INK ROLLER WASHERS

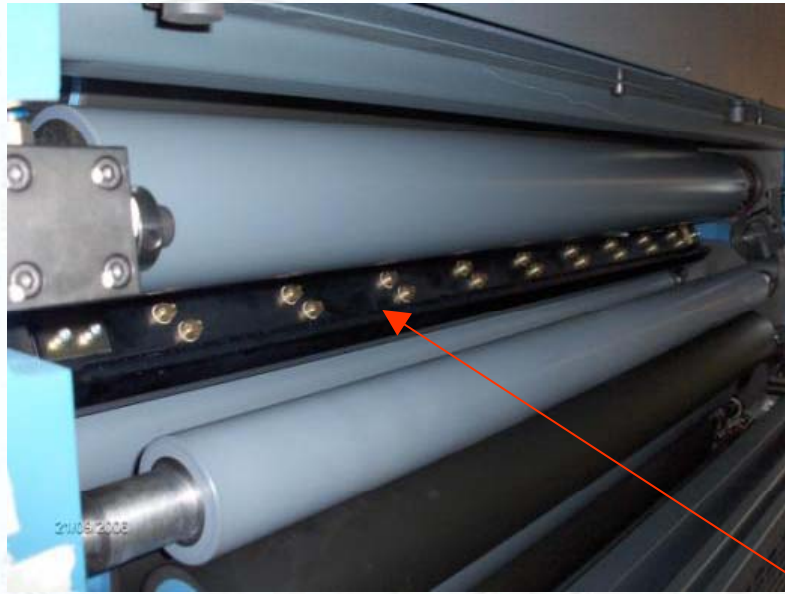

Ink Roller Washer

- Integrated in FastWash system (Touch-Screen & Feedings)
- Spray system with nozzles
- Separate hydraulic circuit with water and solvent
- The operator has to bring the press to the required speed and start the system. Elettra will take care of the proper distribution of cleaning solution and will automatically activate the wiper already installed.

Single device design

- Press speed:
6000 Rev/h
- Possibility of Independent
sprayings (water/solvent)
- Typical washing duration (10
solvent sprayings + 5 water
sprayings): from 3 up to 5 minutes

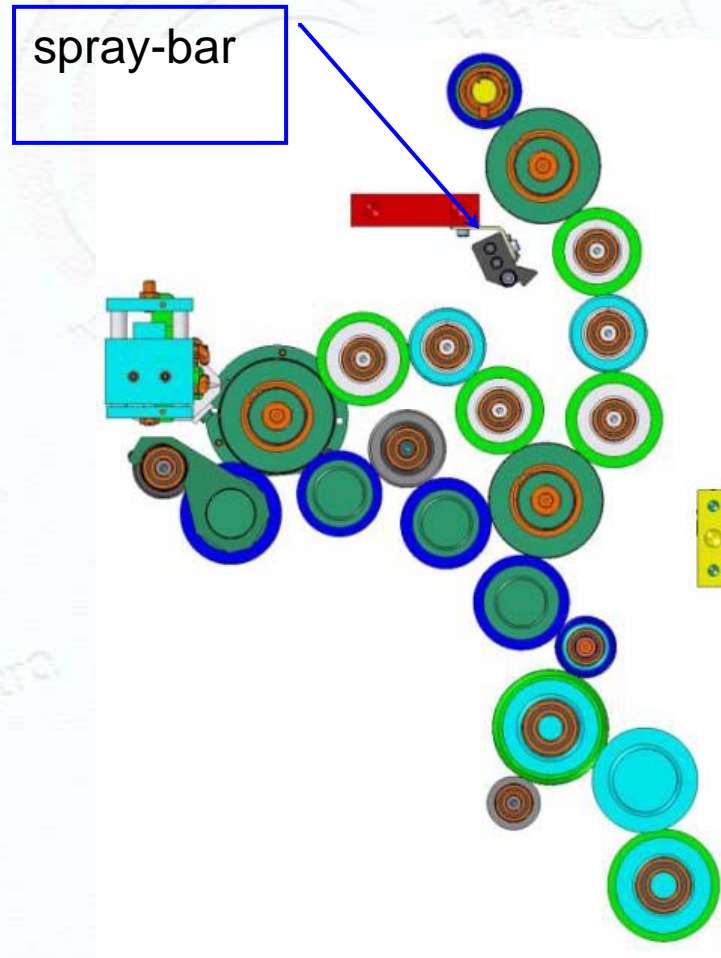



Thank you very much
for your attention...

